



Installation Manual
Wireless Door Sensor
Magnetic

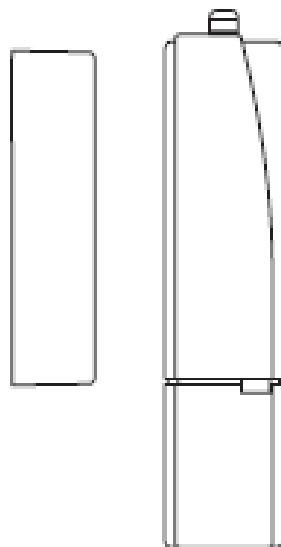

Table of Contents

GETTING STARTED	2
UNPACKING.....	2
MOUNTING.....	3
INSTALLATION OF BATTERIES.....	5
AFTER INSTALLATION OF BATTERIES	5
TESTING THE DOOR SENSOR	6
RESET TO FACTORY SETTINGS	6
MAINTENANCE.....	7
TECHNICAL SPECIFICATIONS	7
SAFE DISPOSAL	7
ACTIVATION IN THE ALARM SYSTEM	7

Getting started

Congratulation with your new SuperSail product. We hope that you will be satisfied with the product and we are always available to give support in case you need it.

You can contact us at: support@super-sail.dk

Regards,

SuperSail Support Team

Please read the whole installation manual before starting the installation.

Unpacking

Before you start using the unit you must ensure that the packaging has not been broken or have been injured during transport and that the product is complete and without any visible sign of damage or strained. If this is not the case please contact SuperSail before using the product.

The Door sensor is a mechanical sensor, which wireless reports status of door/window (open/closed) to the SuperSail Alarm system.

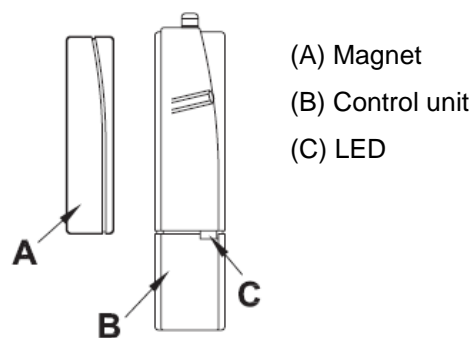

The Door sensor consist of 2 main parts, plus batteries:

- Control unit
- Magnet
- 2 button cell batteries LR44

Material for fastening as well as spacers to make the sensor fit to different doors and windows are included.

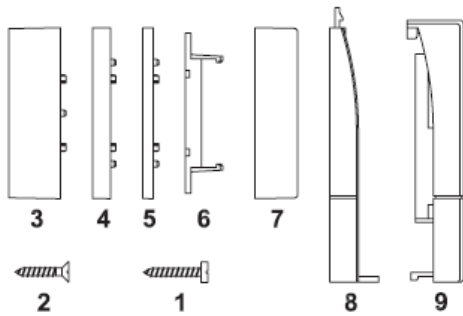

1. 4 pcs. screws 2.2 x 16
2. 2 pcs. screws 2.2 x 13

Spacers to adjust the height of the magnet:

3. Spacer 14.5 mm
4. Spacer 5 mm
5. Spacer 3 mm
6. Magnet
7. Magnet cover
8. Wall bracket
9. Control unit

Mounting

The Door sensor is installed by use of the included screws or for instance heavy two-sided tape. If the spacers are not needed, two-sided tape can be used to prevent damage to the doorframe.

One part of the Door sensor (Control unit or the magnet) is installed on the movable part (door/window) and the other part is installed on the fixed part (doorframe).

When the Door sensor is installed it is important that the magnet is installed correct next to the Control unit as shown in the below figure.

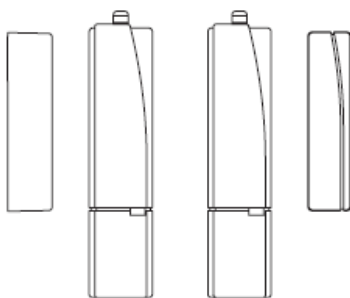

The installation height on the surfaces where the two parts are installed must be equal. This can be achieved by use of one or more of the spacers, which adjust the installation height of the magnet (only by use of screws for installation).

As the spacers are intended for the magnet, the Control unit must be installed on the highest surface and the magnet must be adjusted hereafter.

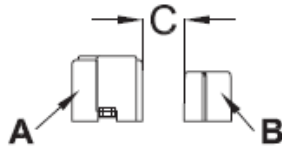

When the door/window is closed, the distance between the Control unit and the magnet must not exceed 8 mm.

Use the short countersunk screws to install the Control unit and the longer screws to install the magnet.

If the parts are installed on hard surface, use a 1.5 mm drill to pilot drill. On soft surface this is not necessary.

Install the bracket for the Control unit with the lock mechanism pointing upward as shown in the figure below.



Push the Control unit gently towards the bracket and push it into place in direction (2), until the lock mechanism locks and fasten the Control unit.

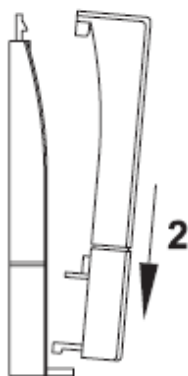

Use one or more spacers (A) if necessary, to adjust the magnet (B) to the right installation height relative to the Control unit (only by use of screws for installation).

Notice!

If the 14.5 mm spacer (A) is used, it must be installed by use of 2 pcs. 2.2x16 mm screws. Hereafter the magnet (B) is installed on top with 2 other screws.

The lower spacers is installed together with the magnet by use of 2 pcs. 2.2x16 mm screws (C).

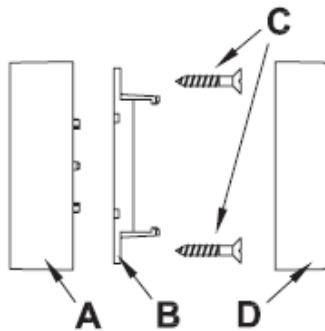

Hereafter the magnet (D) is pushed in over the magnet holder, until it is locked by the magnet holder.

Installation of batteries

Remove the Control unit from the holder, by pushing the lock mechanism in and carefully pulling the Control unit upwards.

Install the 2 included LR44 button cell batteries in the Control unit, as shown at the unit. The batteries are maintained by the spring in the unit.

Notice that the LED on the Control unit is blinking when the batteries are installed correct (see section "After installation of Batteries"). Fasten the Control unit in the bracket again.



Used batteries should not be disposed a domestic waste.

Batteries should be disposed according to the local regulations for batteries

If no reaction is seen in the LED or if the blinking code for battery low is shown, the batteries must be exchanged to new of the type LR44, as described above.

Verify that the batteries are installed and aligned correct.

After installation of Batteries

After installing new batteries, the Control unit will run a self-test. This will normally be finished after approx. 2 seconds.

Faultless execution of the self-test is indicated by blink with the LED: red, green and orange each turned on for 0.5 second.

If an error is discovered by the self-test, this will be indicated by blink with the red light.

1 long blink, 2 short blink, pause (repeated 2 times)	Battery level low Exchange the batteries
1 long blink, 1 short blink, pause (repeated constantly)	Sensor defect Exchange the unit

Even that the battery level is low and as long as the battery level allows for it, the Door sensor will remain active and report status to the Alarm system.

If the Door sensor is not able to send status due to low battery level, the error code will be shown again by the LED.

Testing the Door Sensor

When the Door sensor is installed and activated in the Alarm system, the function of the Door sensor must be tested.

Open the door/window where the Door sensor is installed. Notice that the LED at the Control unit is turned on shortly.

After some seconds (depending on the time for SMS transfer), an Alarm SMS must be received indicating alarm from the Door sensor.

Fault search:

- The yellow light is not turned on when the door/window is opened
Remove the batteries and re-insert them – verify that they are aligned correctly.
Self-test as described above under “After Installation of Batteries”, will verify if there are any faults on the Door sensor.
Verify that the Door sensor is installed correct, as described above under “Mounting”
- Light is turned on, but SMS is not received.
Verify if the Door sensor is activated correctly in the Alarm system, as described below under “Activation in the Alarm system”
Verify that the Door sensor ID is keyed in correctly.

Reset to Factory settings

If the Door sensor for some reason does not function and the batteries have been changed without solving the problem, reset to Factory settings can be a solution to fix the problem.

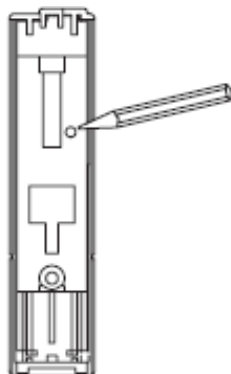

Press and hold the button for 5 seconds, until the LED starts blinking slowly with red light (use a tip pen).

Release the button and push shortly again after 1 second. The LED will stop blinking red.

The Door sensor is reset to Factory settings.

Maintenance

The Door sensor is maintenance free. Repairs should be carried out at an authorized service center.

Cleaning can be carried out with a soft cloth wrenched in lukewarm water.

Cleaning detergent containing solvent can harm the unit.

Technical Specifications

Radio frequency:	868.3 MHz
Typical outdoor range:	100 m
Power:	2 x button cell batteries LR44
Battery life time:	approx. 2 years (at 4 daily activations)
Protection:	IP20
Cabinet:	ABS
Color:	White
Size:	77x17x16 mm (HxBxD)
Weight:	28g (Control unit, magnet, ex. batteries)

Changes may apply.

Safe Disposal



Should not be disposed a domestic waste.

Electronic equipment should be disposed according to the local regulations for electronic and electronically equipment.

Activation in the Alarm system

After installation and test, the Door sensor must be activated in the Alarm system.

This is performed via the SuperSail app, where the Door sensor is activated via the Alarm menu.

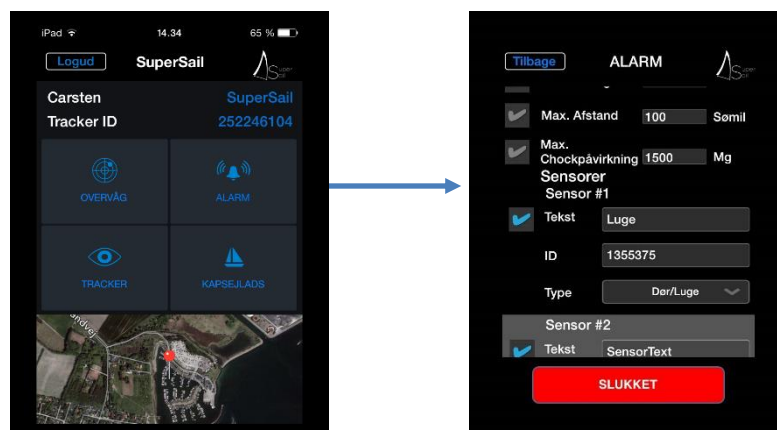

In the above example, we have decided to activate the Door sensor as sensor #1, but all sensors are available for all sensor types.

In the "Text" field you can write a short text, which identifies the installation of the Door sensor. This text will be transmitted in the Alarm SMS in case the Door sensor is activated. It is therefore important that the text identifies the individual Door sensor.

In the "ID" field, you write the ID written on the back of the Door sensor. The ID is furthermore written on the Quick Guide which follows the Door sensor. This ID is unique for the Door sensor and makes it possible for the Alarm system to separate the wireless sensors. Save the ID in case the ID should be deleted from the app and need to be re-installed later.

In the "Type" field you choose "Door", which specifies that the Door sensor is of the type Door sensor.

Finally the sensor is activated by ticking the field next to the "Text" field. This activates the sensor in the Alarm system. When the alarm is turned on, this sensor will be included in the alarm.

It is recommended to activate the alarm and test that an alarm SMS is sent, if the Door sensor is activated.